

# PRODUCT PORTFOLIO

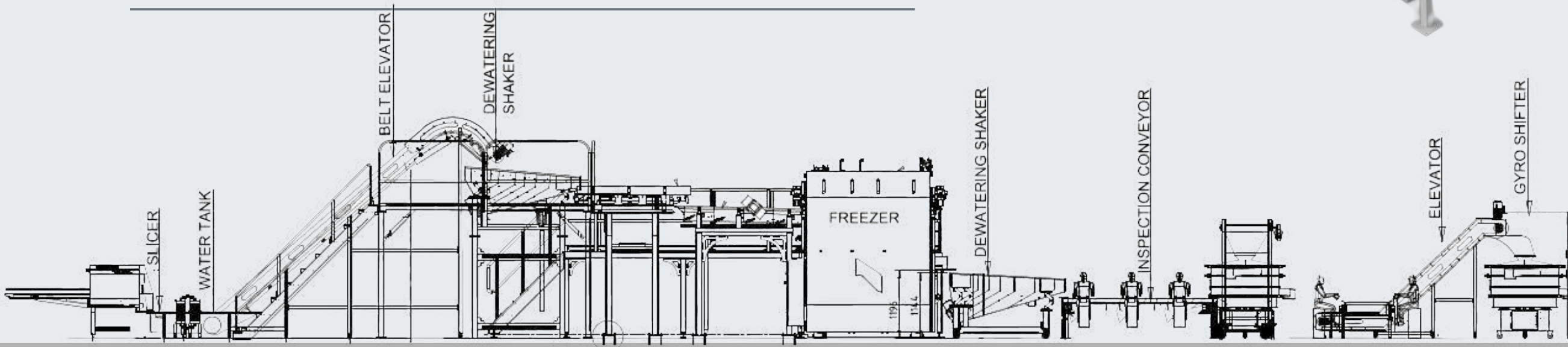

# OUR PRODUCTS

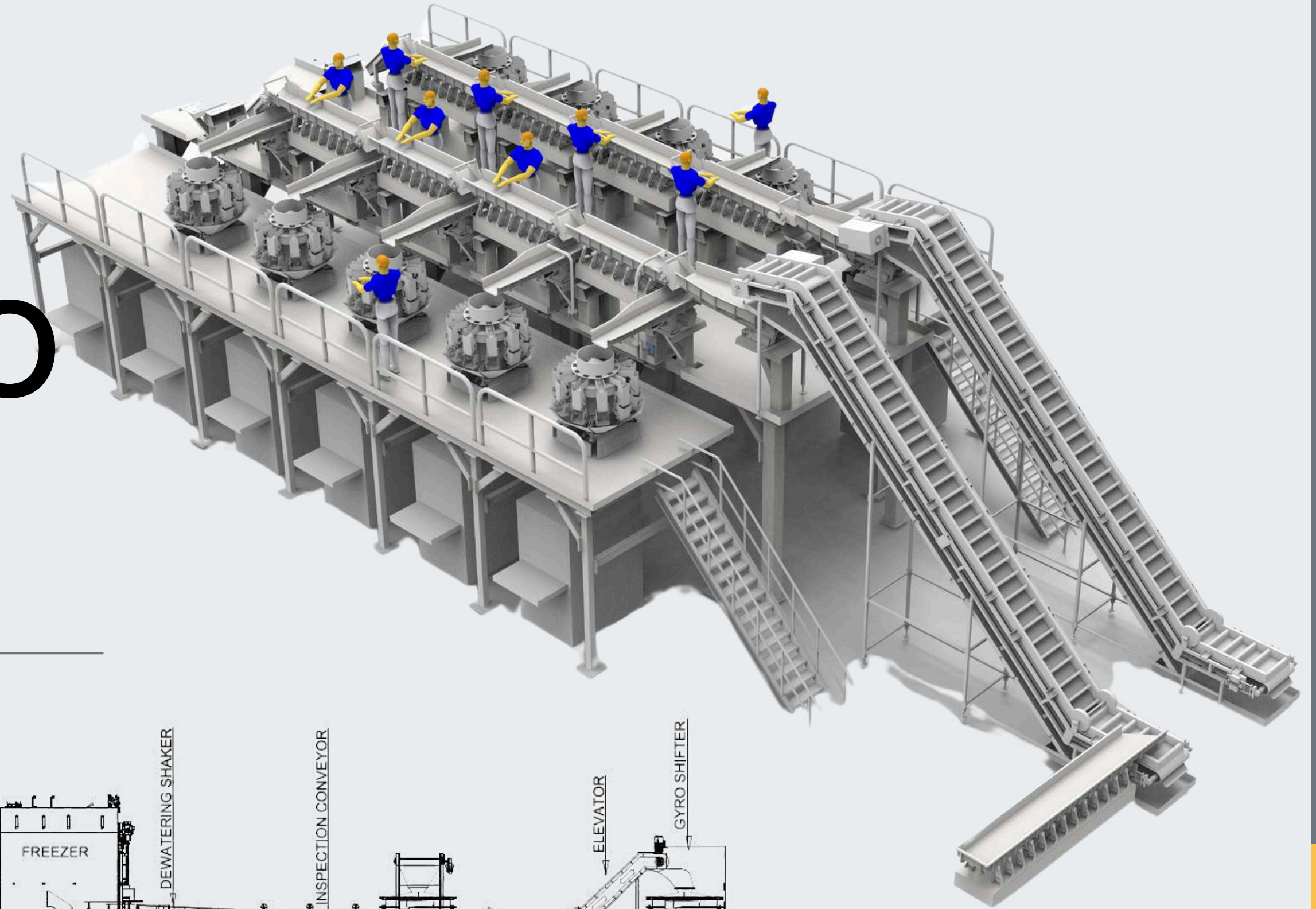

## CONVEYING

Our conveying machines are highly suitable for moving a wide range of materials, including granules, powders, delicate items and many more.



## ELEVATING

Elevate the fragile product to the next level, it is used for elevating, Cooling, drying application. It has various benefits like no moving parts, easy to clean, low vibrating power, High performance.



## SCREENING

There are a variety of screening solutions available with Shri Vibracion Technology, including electromagnetic screening, rotary screening, motorised screening, and vibrating screening.

# OUR PRODUCTS



## SEASONING

In the seasoning process, vibratory feeders are used to convey a controlled amount of seasoning or flavorings onto the snacks. These feeders use vibrations to move and distribute the seasoning evenly, ensuring consistent flavor.



## PART HANDLING SYSTEM

It is designed to streamline material flow, reduce manual labour, and optimise production processes. Our product range, including the Bowl Feeder, Boondi Dripper, Compaction Table, Laning in Feed, and more



## DEWATERING SHAKER

Dewatering shaker is an efficient and convenient machine for removing excess water from products. It utilizes vibration to separate water from solids material, making it fast and efficient.

# OUR PRODUCTS



## AUTOMATION & INTEGRATION

Shri Vibracion Technology is at the forefront of offering automation and seamless integration to redefine your manufacturing processes. Our expertise extends beyond individual systems to create a connected and efficient production environment. With a focus on user-friendly controls, our automation solutions



## SMALL TURNKEY PROJECTS

Shri Vibracion Technology emerges as a pioneer in completing turnkey projects. Our commitment to turnkey solutions encompasses a comprehensive approach, from design and development to seamless integration and operational readiness.

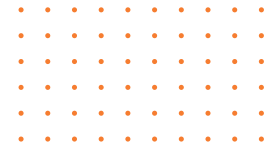

# **BENEFITS**

---

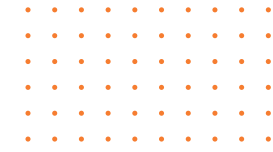

**Faster ROI**



**Ergonomic  
design**



**Maintenance  
Free**



**Easy to install**



**High  
Performance**



**Low power  
consumption**

# NUBIN GRADER

Nubin grader widely been used to grade the fries length wise and it helps in packing good and acceptable quality product which is the key factor for any manufacturer.

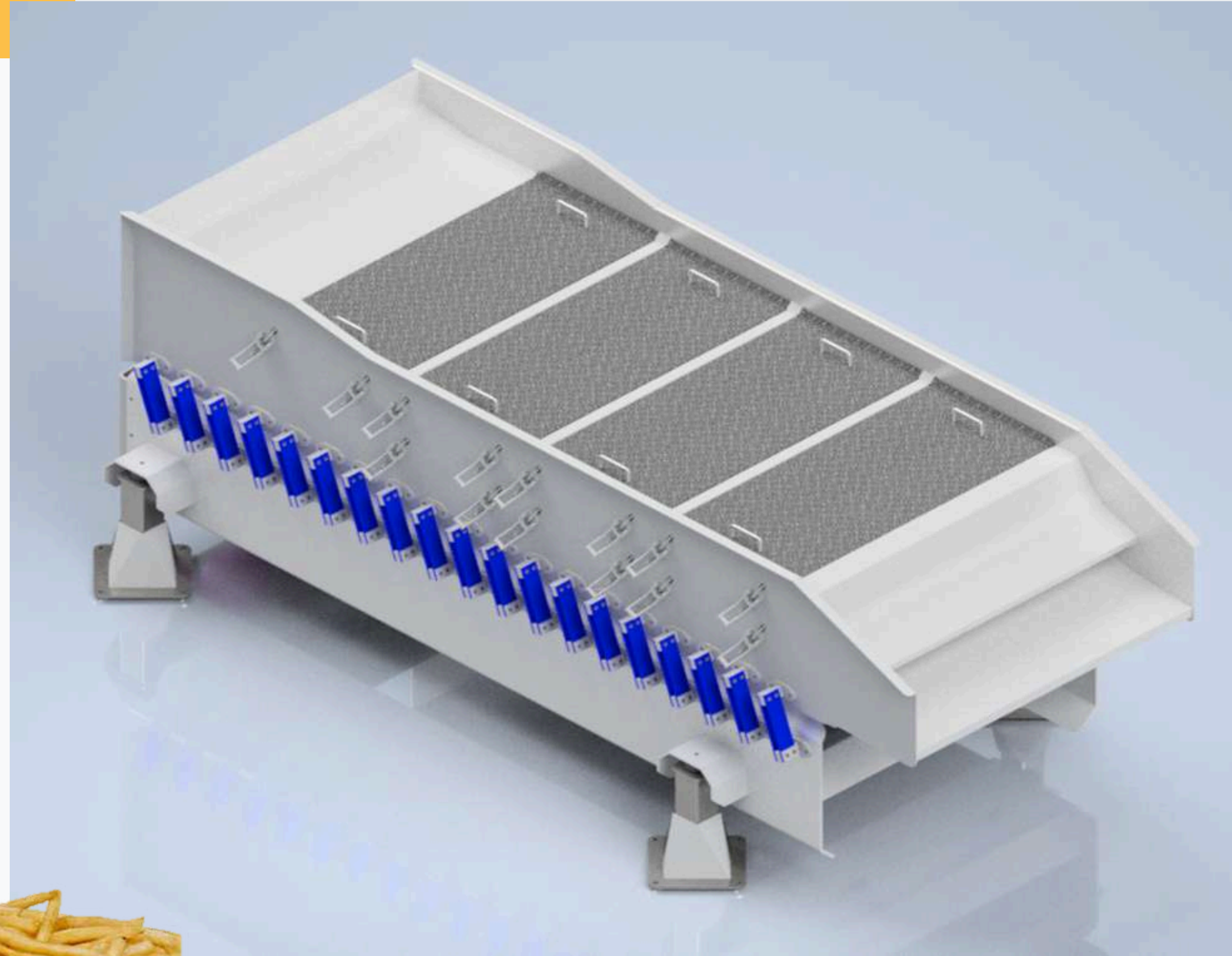

Elevate your food manufacturing with this game-changer for grading fries lengthwise. Only the finest, top-quality products make it to your table.

# VIBRATORY DISTRIBUTION SYSTEM

Elevate your production efficiency with our Vibratory Distribution System- seamlessly delivering products to multi-head weighers.

- no seasoning loss.
- ensuring faster ROI.
- and delivering precise.
- effortless operations to enhance your overall productivity.



# DRY FRUIT CLEANING, GRADING, AND MANUAL INSPECTION SYSTEM

- Upgrade new Standard in Cleaning and Grading
- Say Goodbye to Unwanted Materials
- Manual Inspection for Unsurpassed Quality
- Maximize Efficiency, Minimize Defects.

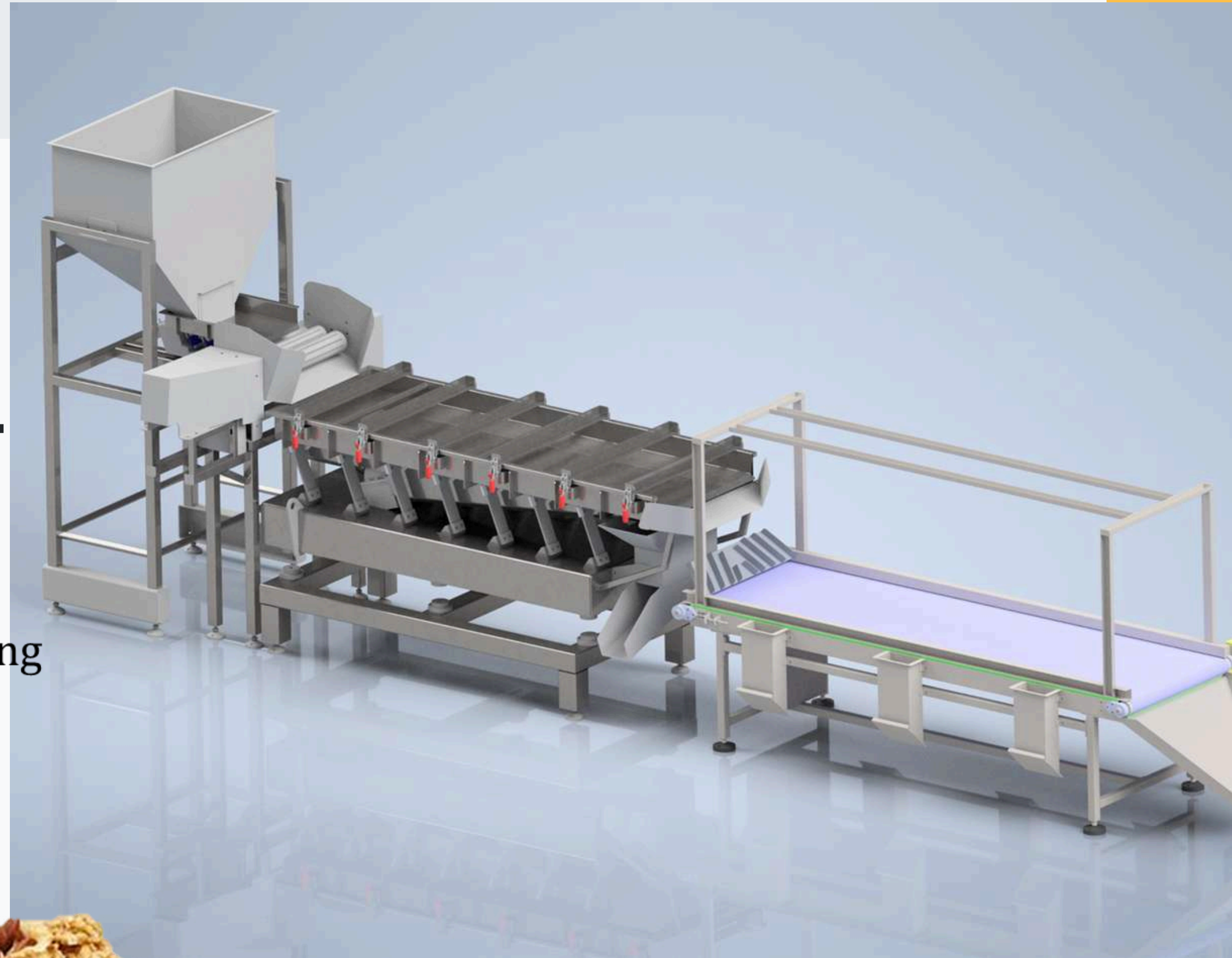



# FEEDERS.



## 01 EASY TO INSTALL

- Capacity ranging- 0.5 Kg to 20 TPH.
- Our Feeder set specifically designed to require minimal installation time and effort.
- accurate and consistent feeding in various industrial processes.

## 02 LOW POWER CONSUMPTION

- Require minimal power for operation.
- Environmental friendly

## 03 MAINTENANCE- FREE

- long-term reliable performance without any trouble.
- Cost savings.



# CASHEW CLEANING SYSTEM

- **High Throughput**
- **Improved Productivity**
- **Reduced Labor Costs**
- **Energy Efficiency**
- **Precision and Efficiency**
- **Low Maintenance**



# ELECTROMAGNETIC SCREENING

Our electromagnetic vibratory screening effortlessly removes the impurities, ensuring only the finest materials pass through. With its seamless operation it elevates screening capabilities and maximizing fine product output.



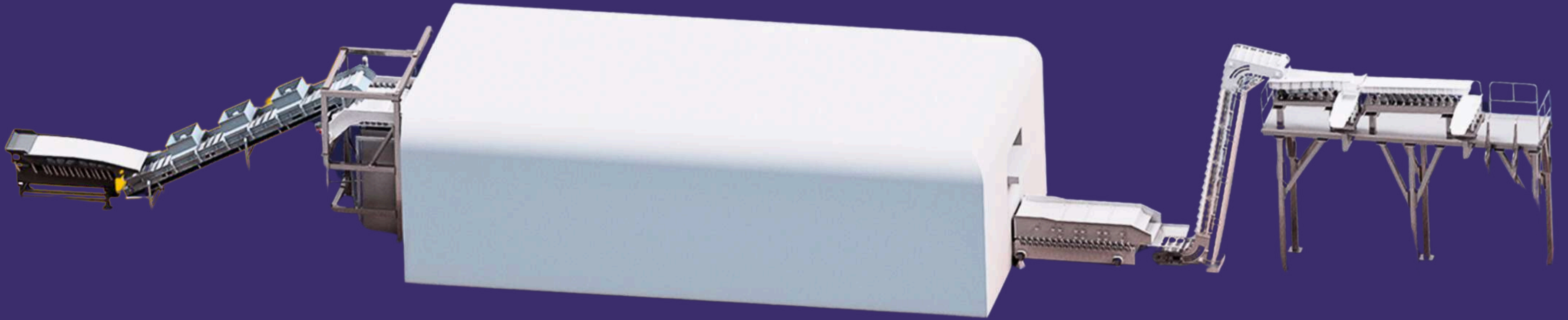
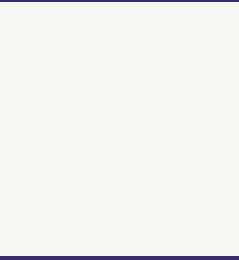

# IQF MATERIAL HANDLING SYSTEM

Our Vibratory Machinery for Ready-to- use Frozon Products

Products:



# ON SITE INSTALLATION

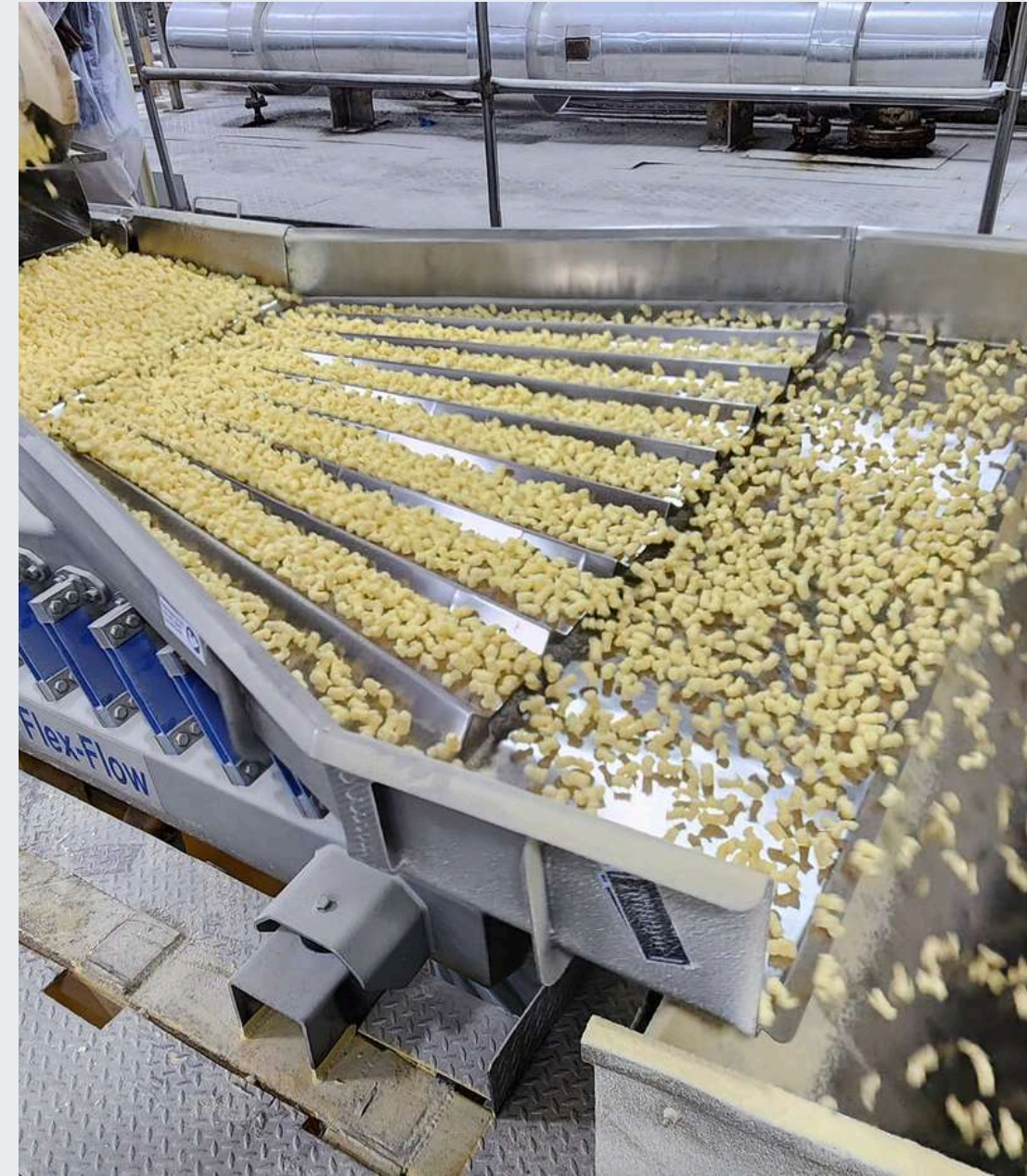
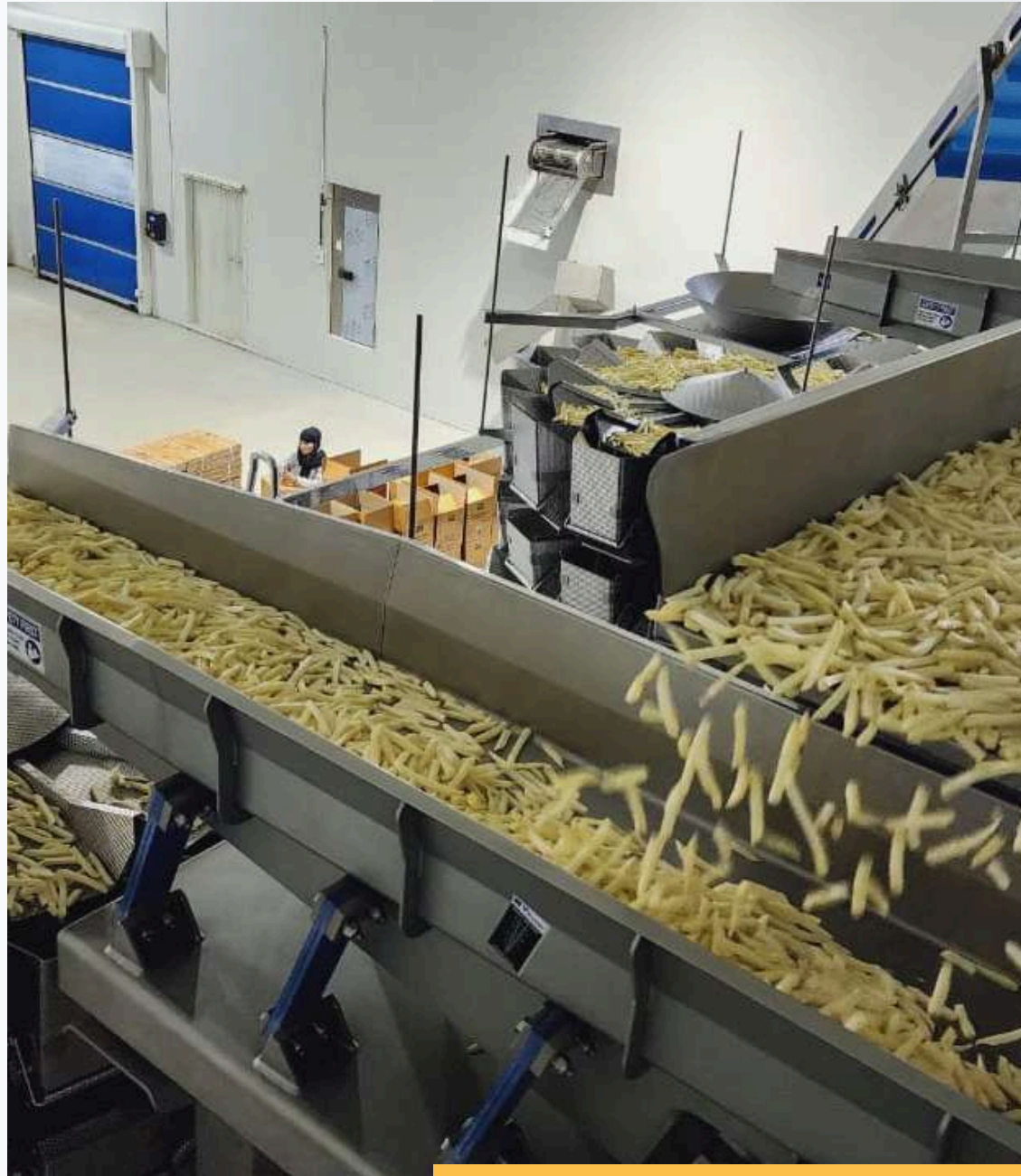

# ON SITE INSTALLATION



# ON SITE INSTALLATION



# SMALL TURN KEY PROJECTS

Introducing our small turnkey projects, where we handle equipments & ensure every project is completed efficiently and meet customer 's exact specifications.

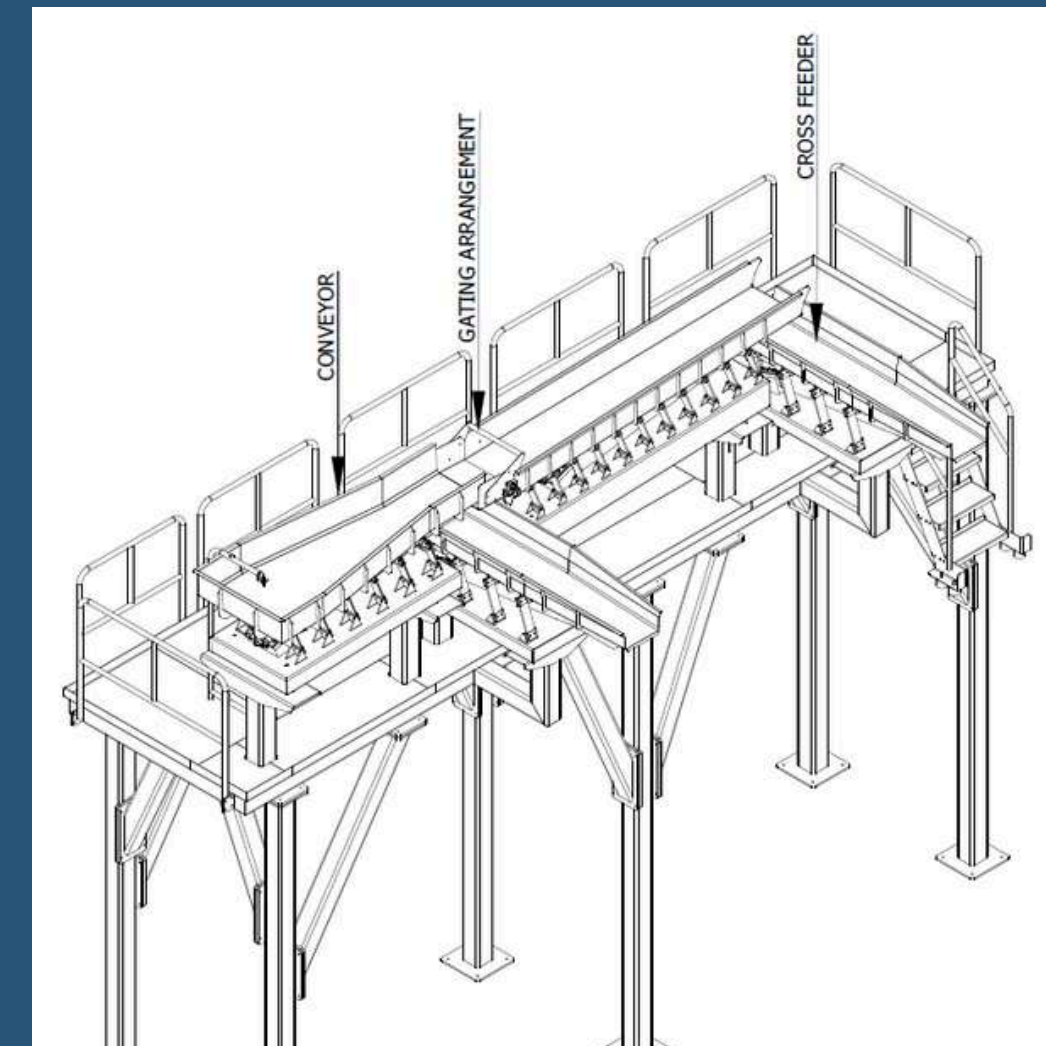
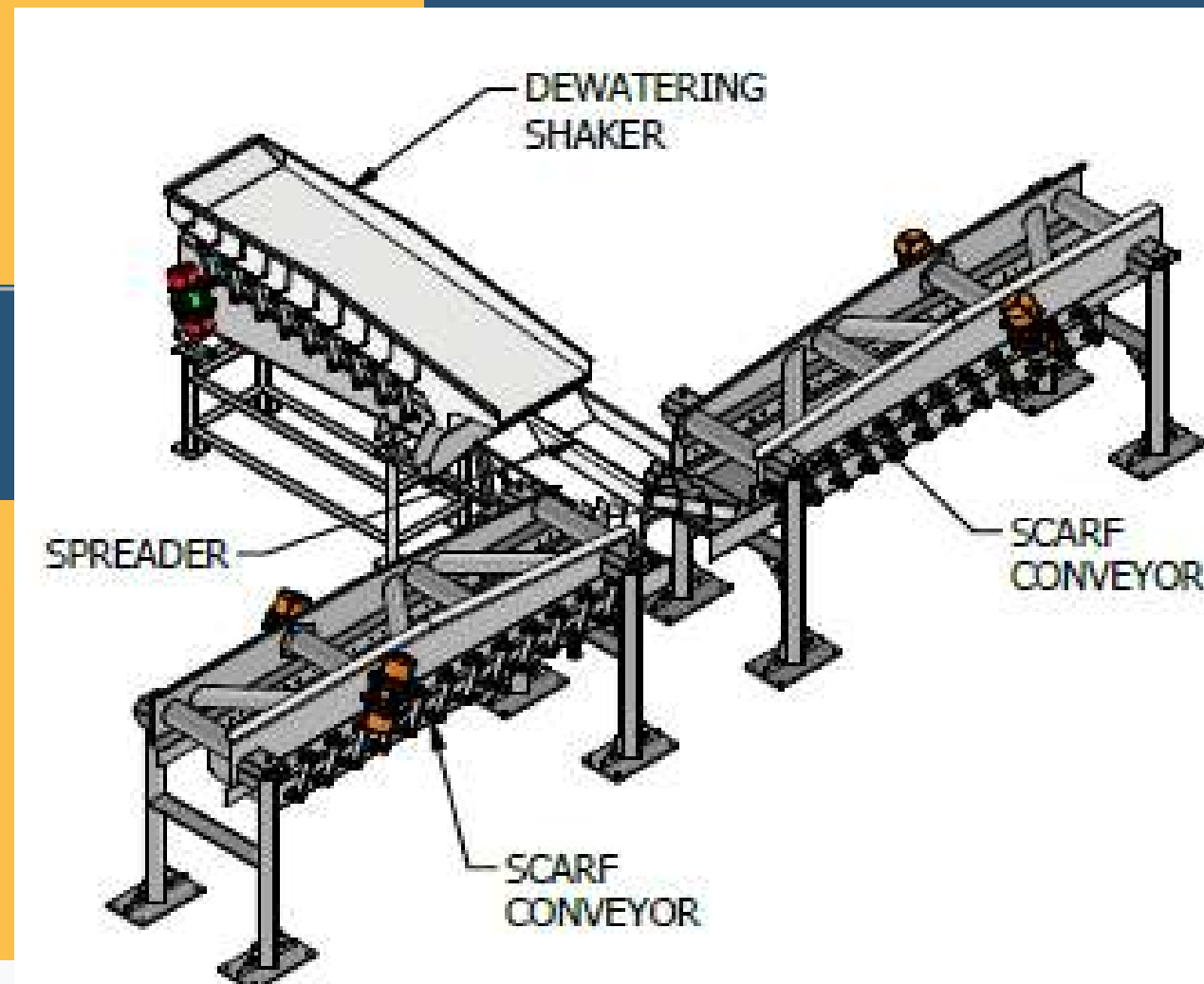
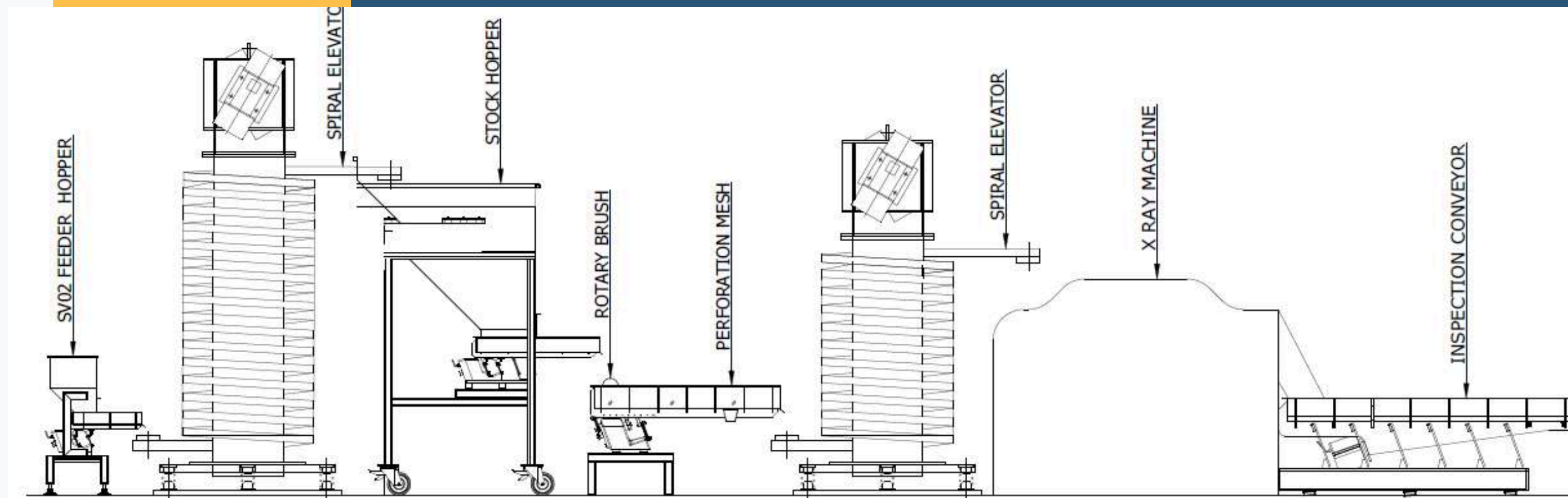



# SMALL TURN KEY PROJECTS

We specialize in delivering comprehensive solutions tailored to your needs, from conception to completion.

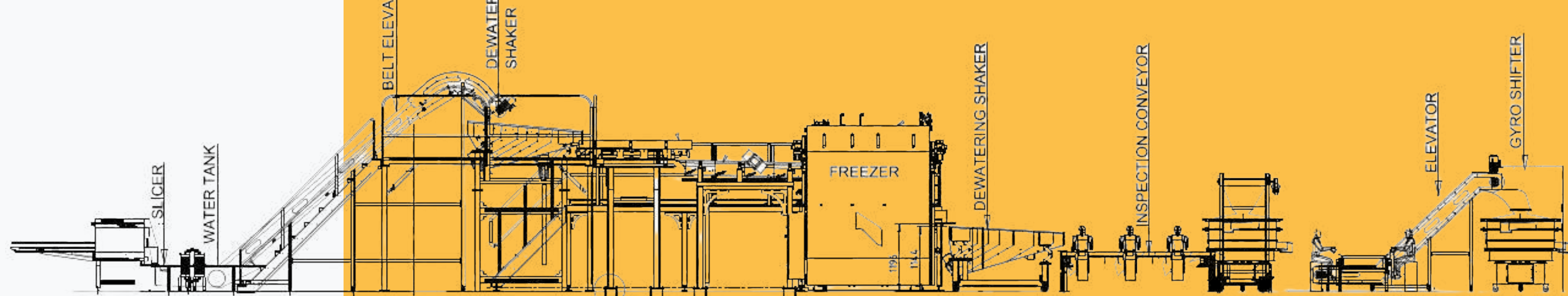
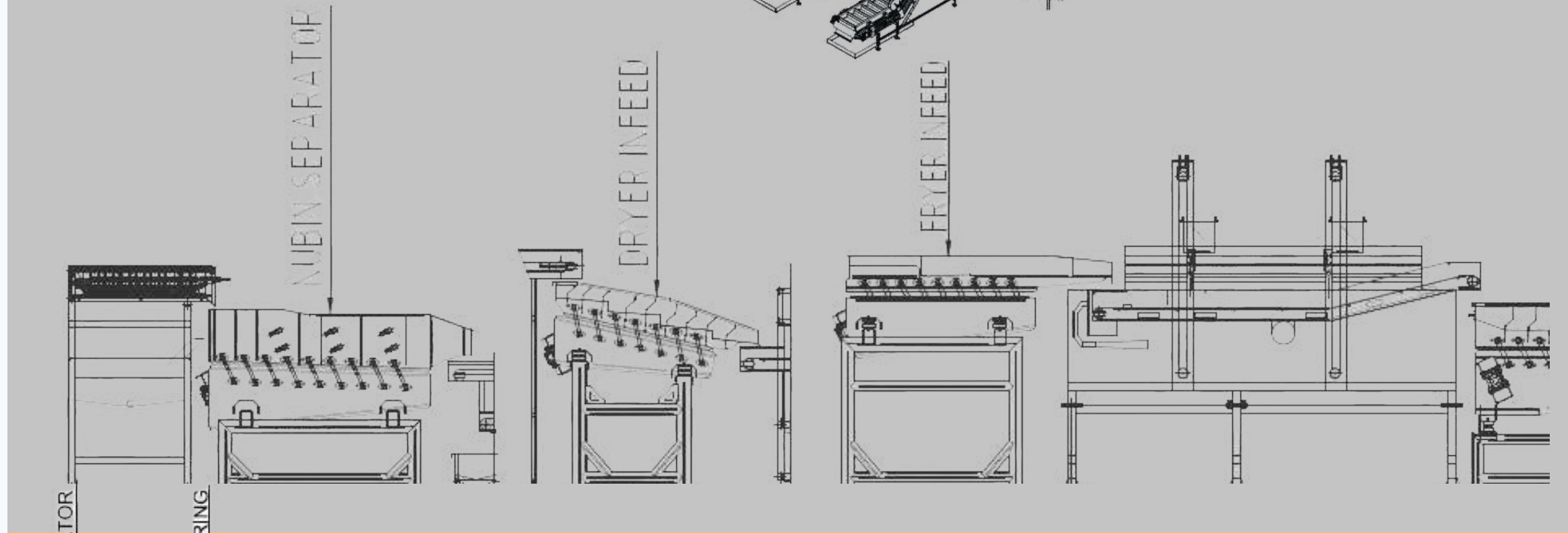
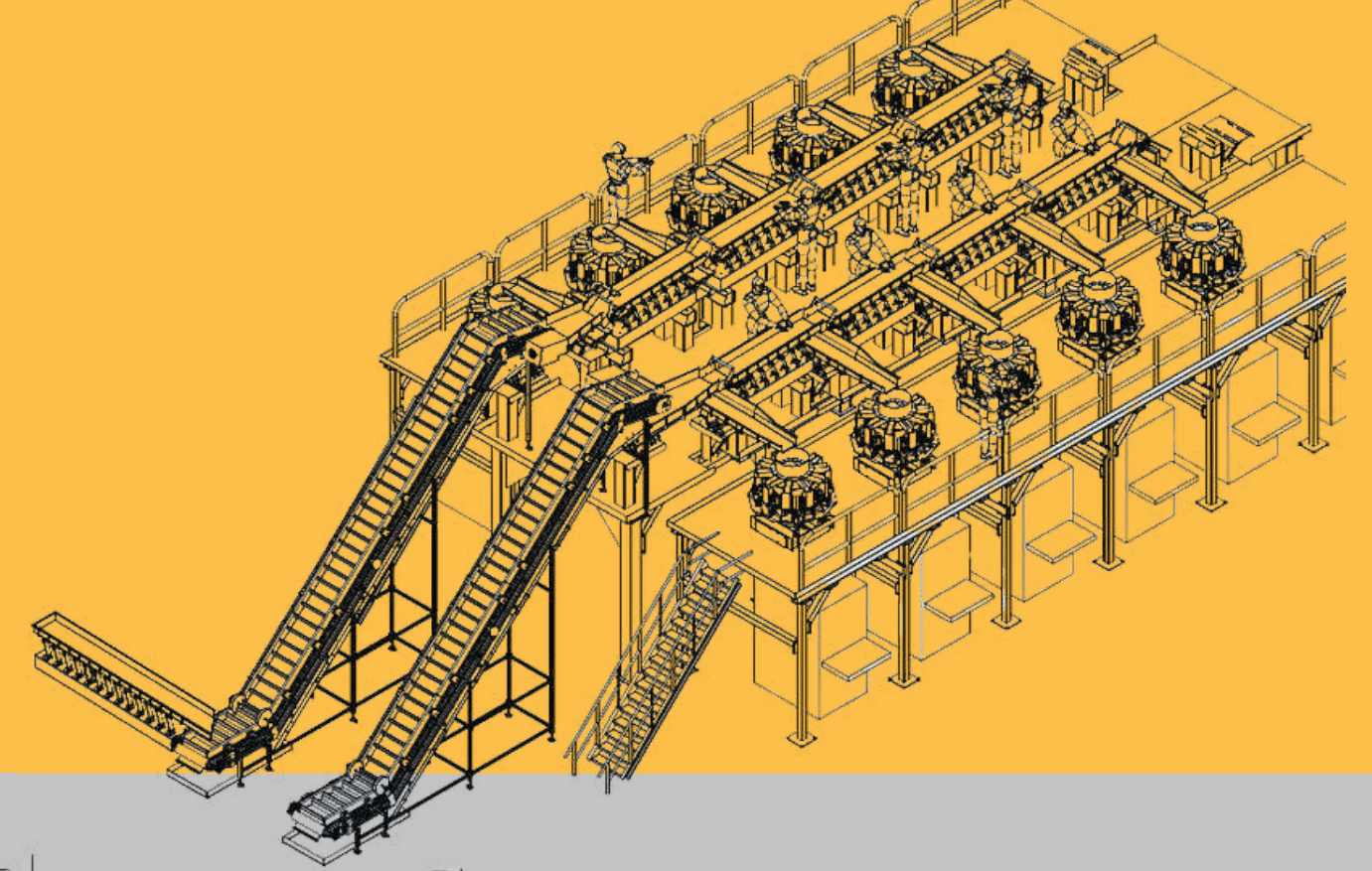

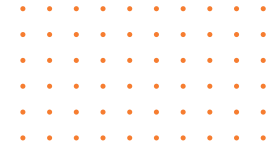

# CONTACT US

Have a query or need assistance,  
Reach out to us today. Our team is ready to help.



+91 9325053539



[www.linearvibratoryfeeder.com](http://www.linearvibratoryfeeder.com)



[info@shrivibracion.com](mailto:info@shrivibracion.com)



Pune, Maharashtra

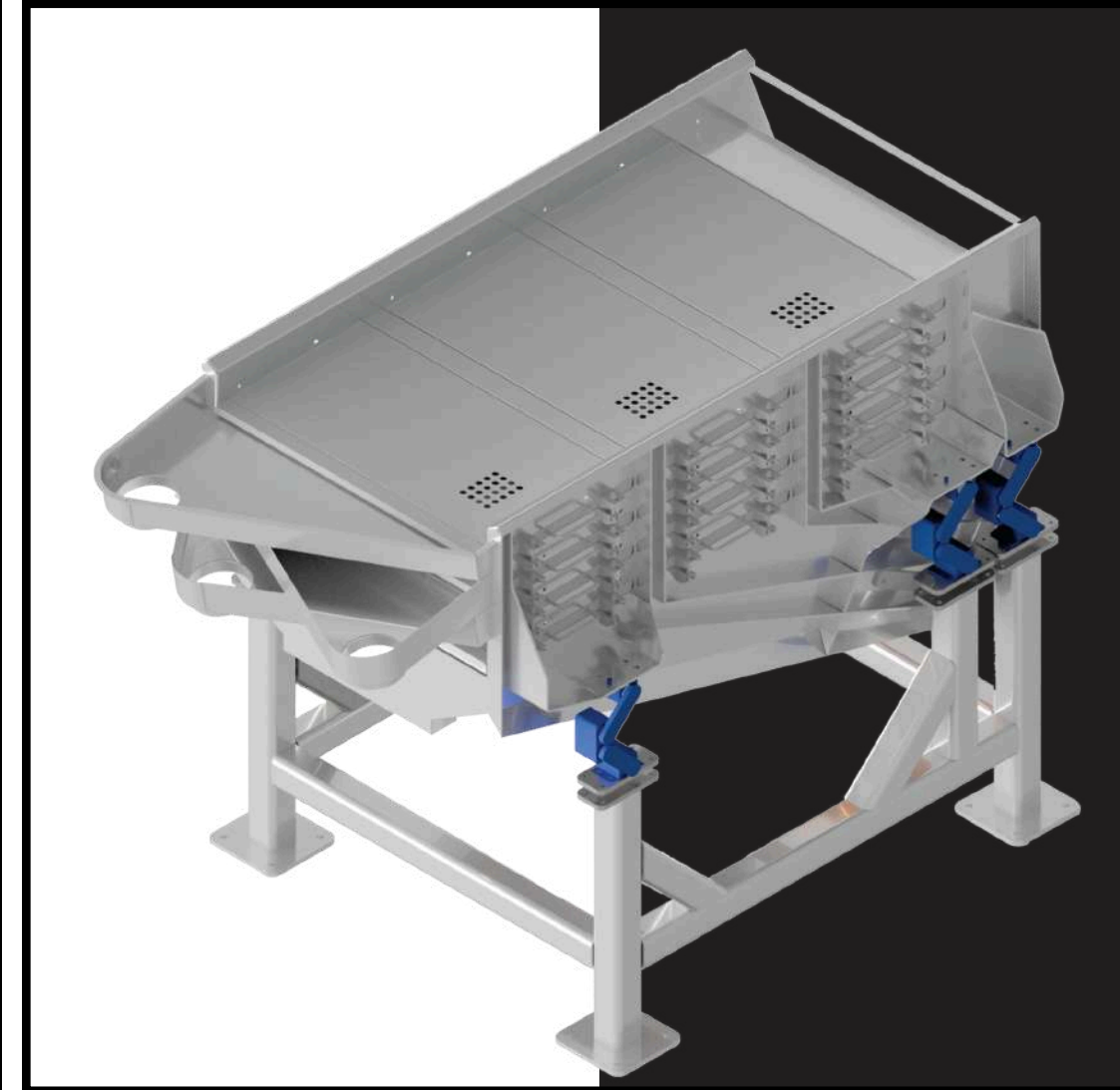



# THANK YOU

---

